

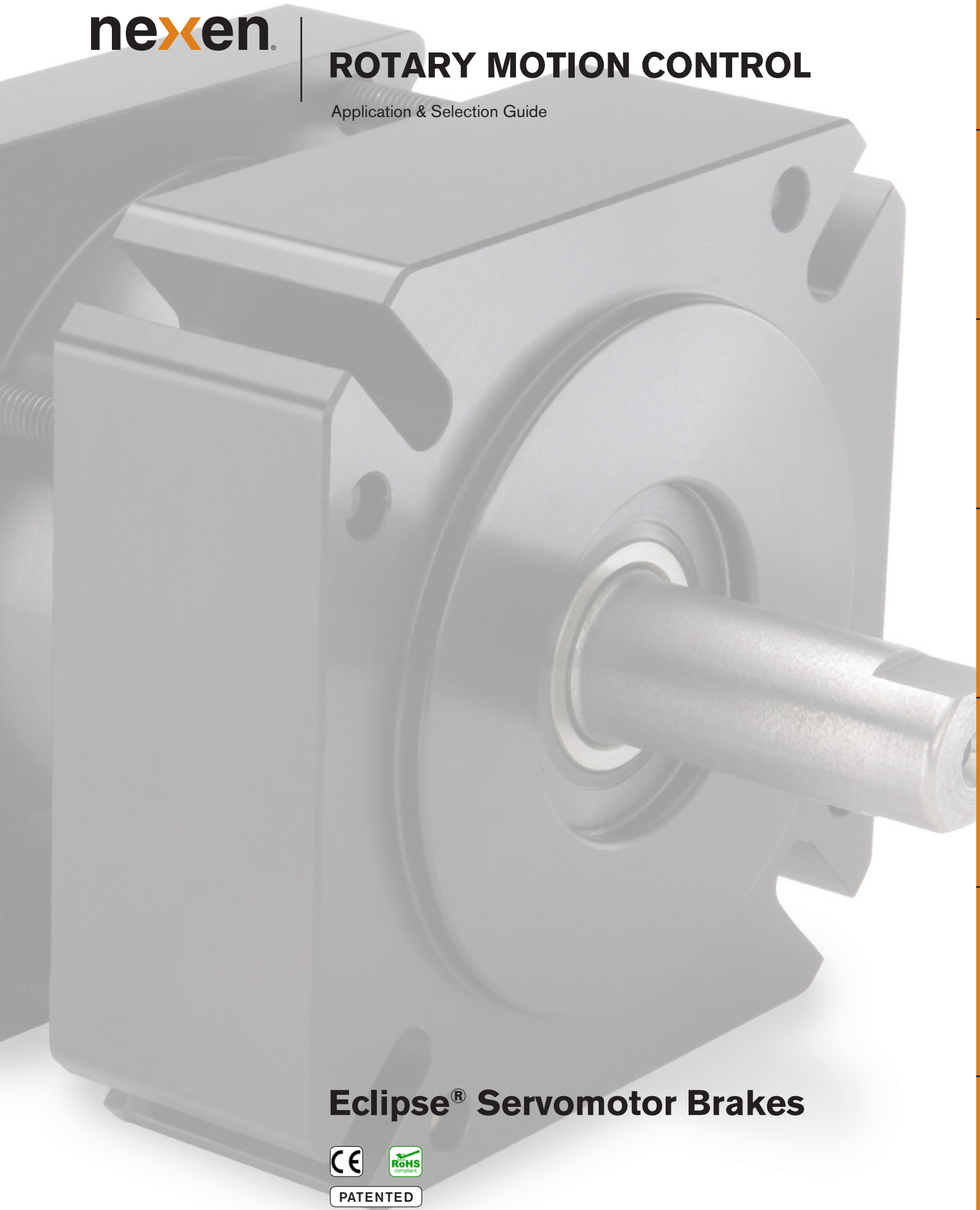

ROTARY MOTION CONTROL

Application & Selection Guide



Eclipse[®] Servomotor Brakes



PATENTED

Features

2

Cross-Sectional
Drawings

4

Dimensions

5

Specifications

11

Solenoid Valve

14

APPENDIX:
Definitions

15

Contact
Information

16

The Nexen Eclipse® Advantage

Tracing its roots back to 1902, Nexen's long history of innovation and quality show a legacy of advancing the motion control industry through its commitment to product development.

Continually testing and improving products as well as developing new technology, Nexen's contribution to the industry is now illustrated in the expanded Eclipse® line of servomotor brakes. With over 140 models in seven bore sizes, Nexen offers an **off-the-shelf braking solution for any servo application.** These spring-engaged, air released brakes eliminate the performance problems associated with electrical brakes for consistent, long lasting performance.

WASH-DOWN PROTECTION
Sealed housings offer environmental protection and meets IP67 dust and waterproof standards. Optional nickel plating also available.

SMOOTH TORQUE TRANSMISSION
Double-taper facing locks down on the housing and rotor to create a zero-backlash torque transmission interface.

COOL OPERATION
Air release disengagement adds no heat, providing cool operation and long life.
Standard electric brakes generate heat when disengaged, lowering the efficiency of the unit. The air-release design of the Eclipse® models requires no energy for operation, resulting in higher, more consistent torque capabilities.

ZERO BACKLASH
The easy to install, keyless split-hub shaft collar prevents backlash for smooth stopping and precision holding.

LOW INERTIA
One-piece rotor/shaft assembly lowers inertia and eliminates spline for zero backlash.

RUGGED STRENGTH
One piece, solid shaft increases torsional rigidity and overhung load capabilities.

Easy Installation. Maintenance Free. Eclipse® Servo Brakes Simplify Excellence.

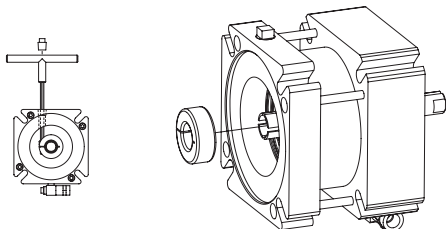

From product selection to installation and maintenance, Nexen designed its Eclipse Servomotor Brakes with ease-of-use in mind.

SELECTION

A variety of sizes, mounting configurations and torque offerings, make retrofits on existing machines quick and easy.

This vast array of flange options transforms what was once custom design into Eclipse® standard. No special ordering. No lengthy waiting. Eclipse® saves you time, consolidates resources, and lowers inventory costs.

INSTALLATION

The brake flange replicates the servomotor flange, so no accommodations are needed. Simply slide the brake between your motor and gearbox and tighten the shaft collar.

Operators will appreciate the true pilot mounting and seamless integration with IEC or NEMA frame motors.

MAINTENANCE

While field serviceable, the long facing life and lubrication-free operation of this line of servomotor brakes make it virtually maintenance-free.

Nexen brakes simplify machine maintenance by holding the load during motor change-outs, even in power-off situations.

Eclipse® Brakes offer at least 20-50% more torque than competitive brakes.

Standard Electric Servomotor Brake
limited torque capabilities

Static Torque up to 125 Nm



Nexen Eclipse® Servomotor Brakes

Dependable Power Ensures Safety

When it comes to service factor, Nexen believes more is better. More torque and high brake stiffness mean operators and equipment are protected.

Strong enough to stall a servomotor in continuous torque mode, the high torque ratings on Eclipse® brakes provide fast response with a short stopping distance in emergency situations. In fact, Nexen's servomotor brakes deliver at least 20-50% more torque than competitive brakes.

In emergency stopping situations, Eclipse® brakes stop the load(s) quickly and safely with bidirectional braking capabilities.

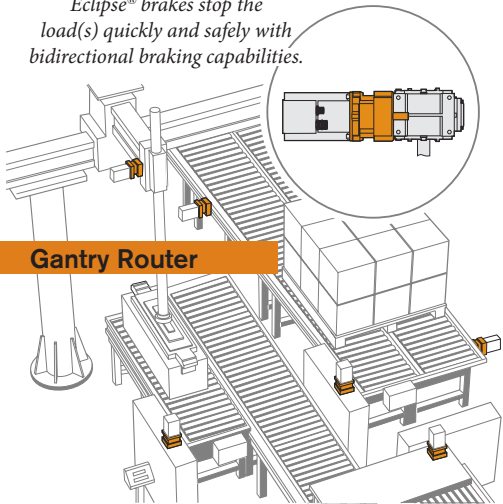

Gantry Router

Able to repeatedly stop and hold in challenging cyclic operations, Nexen Servomotor Brakes also offer a safety feature to this robot: if a belt breaks, the servomotor brake(s) instantly engage to hold the load securely.

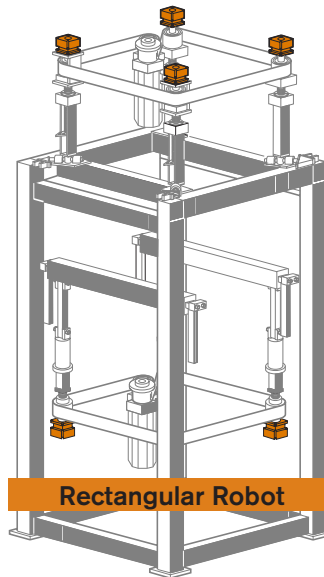

Rectangular Robot

With fail-safe reliability, Eclipse® servomotor brakes hold each joint securely to prevent any arm movement during power-off situations.

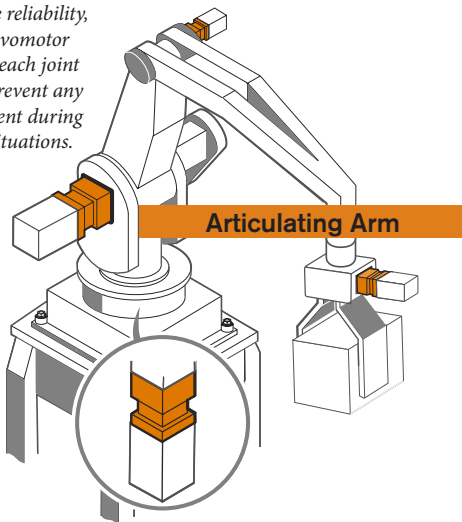

Articulating Arm

Dynamic Stopping

Medical Devices

Food Production

Automotive Parts

Renewable Energy

Semiconductors

Printing

Paper Converting

CNC Machining

Packaging

Machine Tool

Robotics

Woodworking

Conveying

APPLICATIONS

Precision Holding

Eclipse® Brake Cross-Sectional Drawings

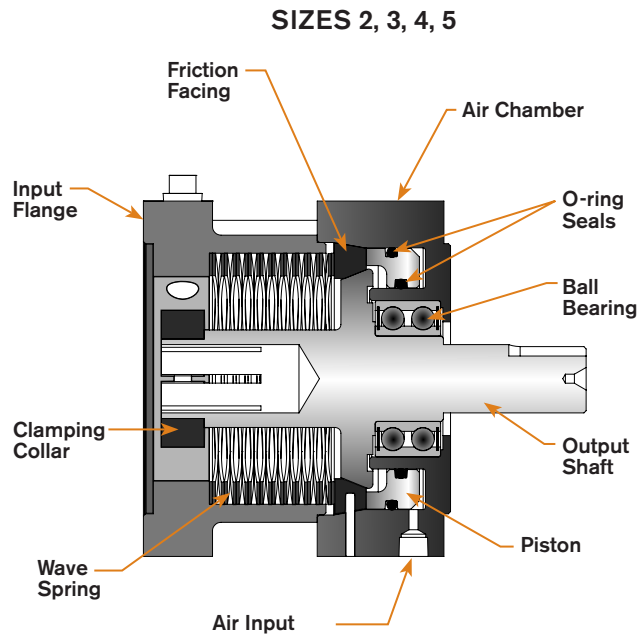

NOTE: Size 5 contains a single row, deep groove ball bearing. Sizes 2,3 and 4 contain a double row.

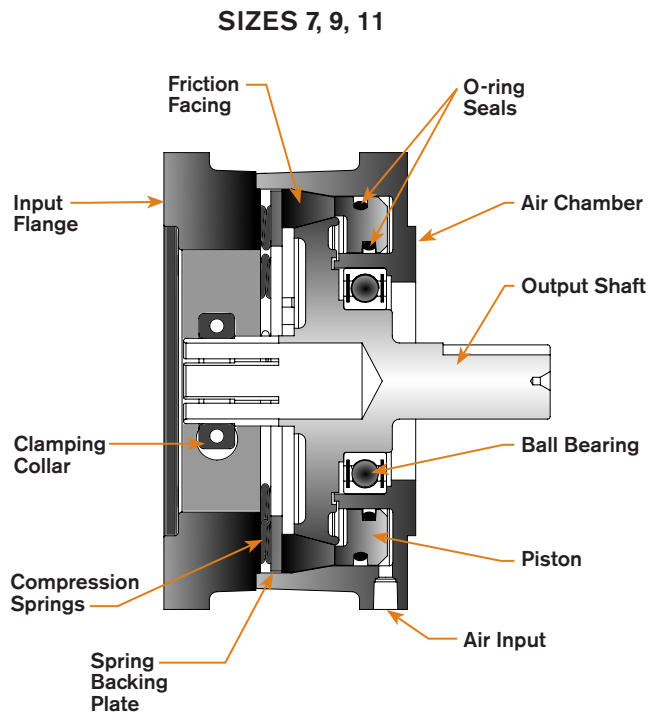

Eclipse® Dimensions

The following section contains the approximate dimensions for each size of Nexen's Eclipse® Servomotor Brakes. Always verify product information with the user manual when specifying a new brake into your application. Refer to www.nexengroup.com for user manuals, product dimensions and specifications.

Servomotor Brake Approximate Dimensions (NEMA Square Flange Motors)

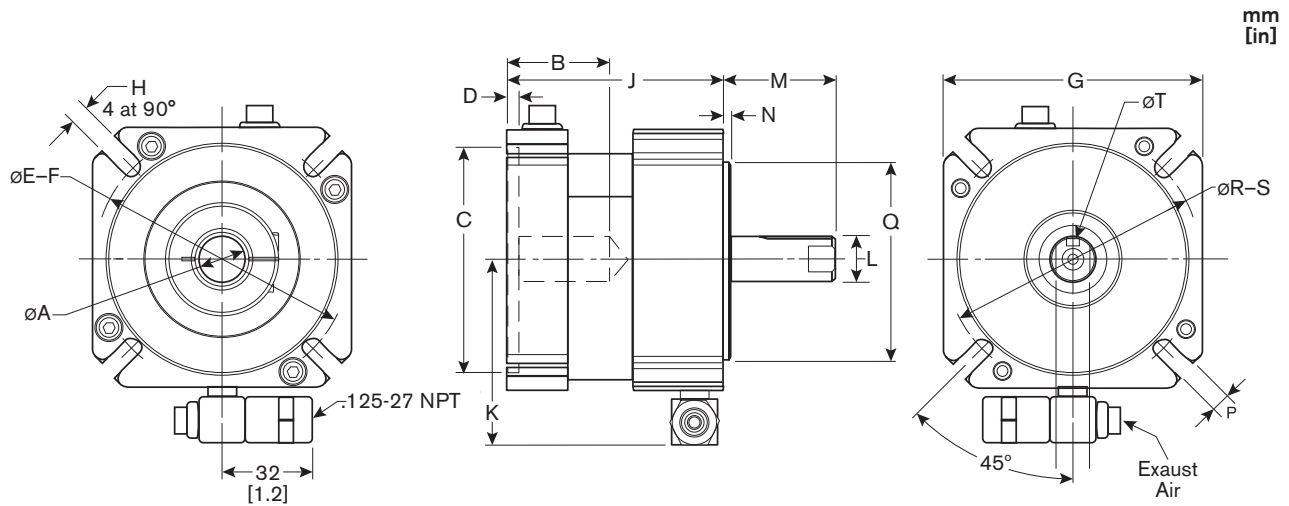

NEMA Square Flange		NEMA Size 23			NEMA Size 34				NEMA Size 42		
Nexen Model		SBP-2			SBP-3				SBP-4		
A	Bore Diameter	0.25	0.312	0.375	0.375	0.5	0.5	0.625	0.625		
B	Bore Depth	1.43			1.46				2.2	2.5	
C	Pilot (female)	1.5			2.875				4.331	2.189	
D	Pilot Depth	--	0.11	--	0.16	0.2	0.16	0.2	0.138	--	
E-F	Bolt Circle Diameter	2.625			3.346-4.280				4.950-5.904		
G	Flange Width	2.25			3.62				4.92		
H	Bolt Hole	10-24			0.28				0.49		
J	Length	2.77			3.06				4.23		
K	Quick Exhaust	1.99			2.6	2.6	3.62	2.3	3.2		
L	Shaft Diameter	0.25	0.312	0.375	0.5	0.5	0.625	0.625	0.625		
M	Shaft Length	1.25			1.25	1.2	1.2	1.18	1.5	2.063	
N	Pilot Extension	0.095			0.12	0.12	0.16	0.12	0.12	0.18	
P	Bolt Hole	0.197			0.233				0.39	0.375-16	
Q	Pilot (male)	1.5			2.875				2.187	4.5	
R-S	Bolt Circle Diameter	2.625			3.875-4.280				4.950-5.904	5.875	
T	Keyway	none			none	0.125	0.125	0.189	0.189		
Product Number		964606	964611	964605	964729	964728	964722	964726	964833	964835	

NOTE: Dimensions for NEMA brakes are shown in inches.

Servomotor Brake Approximate Dimensions (IEC Square Flange Motors: sizes 2 & 3)

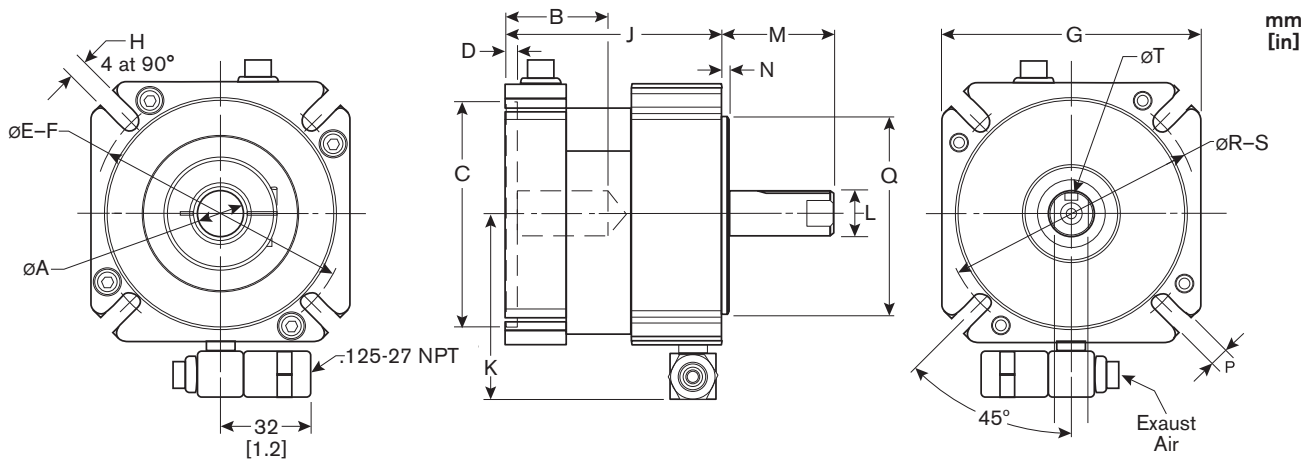

Size 2

Product Number	BORE DIA.	BORE DEPTH	PILOT (female)	PILOT DEPTH	BOLT CIRCLE DIAMETER	FLANGE WIDTH	BOLT HOLE	LENGTH	QUICK EXHAUST	SHAFT DIA.	SHAFT LENGTH	PILOT EXT.	BOLT HOLE	PILOT (male)	BOLT CIRCLE DIAMETER	KEYWAY
	A	B	C	D	E-F	G	H	J	K	L	M	N	P	Q	R-S	T
964610	9.0	35.9	40	2.4	63	57.2	10-24	70.4	50.6	9.0	20	2.4	0.205"	40	63	no key
964615	9.0	35.9	40	2.4	63	57.2	M4	70.4	50.6	9.0	20	2.4	0.205"	40	63	no key
964612	9.0	37	50	2.4	70	57.2	M5	70.4	50.6	9.0	25	2.4	0.250"	50	63	no key
964617	11.0	33.1	60	3.5	70-91.5	74.2	0.250"	74.5	57	11.0	23	1.5	6	60	75-91.5	4.0
964614	11.0	33.1	60	3.5	70-91.5	74.2	0.250"	74.5	57	14.0	30	1.5	6	60	75-91.5	5.0
964613	14.0	33.1	50	3.5	63-91.5	74.2	0.250"	74.5	56	14.0	30	1.5	6	50	70-91.5	5.0

Size 3

Product Number	BORE DIA.	BORE DEPTH	PILOT (female)	PILOT DEPTH	BOLT CIRCLE DIAMETER	FLANGE WIDTH	BOLT HOLE	LENGTH	QUICK EXHAUST	SHAFT DIA.	SHAFT LENGTH	PILOT EXT.	BOLT HOLE	PILOT (male)	BOLT CIRCLE DIAMETER	KEYWAY
	A	B	C	D	E-F	G	H	J	K	L	M	N	P	Q	R-S	T
964721	10	37	80	5	90-109	92	7.0	77.7	65	10	30	3.0	7.0	80	100-109	3.0
964717	13	37	2.875"	4	85-109	92	7.0	77.7	65	13	30	3.0	5.9	2.875"	100-109	5
964713	14	37	50	5	95-109	92	7.0	77.7	65	14	30	3.0	7.0	50	95-109	5
964714	14	37	70	4	85-109	92	7.0	77.7	65	14	30	3.0	7.0	70	85-109	5
964709	14	37	80	5	90-109	92	7.0	77.7	65	14	30	3.0	7.0	80	100-109	5.0
964710	14	37	80	5	90-109	92	7.0	77.7	65	14	30	3.0	7.0	80	100-109	5.0
964724	14	40	80	8	90-109	92	7.0	80.7	65	14	30	3.0	7.0	80	100-109	5.0
964718	14	37	2.875"	4	85-109	92	7.0	77.7	65	14	30	3.0	5.9	2.875"	98-109	5.0
964725	14	37	60	4	85-115	92	7.0	77.7	65	14	30	3.0	5.9	2.875"	98-109	5.0
964727	14	37	80	5	90-109	92	7.0	77.7	65	14	30	3.0	7.0	80	100-109	5.0
964716	0.625"	37	80	5	90-109	92	7.0	77.7	65	0.625"	30	3.0	5.9	2.875"	98-109	.188"
964720	16	42	80	5	90-109	92	7.0	77.7	65	16	40	3.0	7.0	80	100-109	5.0
964712	16	42	80	5	90-109	92	7.0	77.7	65	16	40	3.0	7.0	70	90-109	5.0
964711	16	45	80	5	90-109	92	7.0	69.9	65	16	40	3.0	7.0	70	90-109	5.0
964715	16	42	80	5	90-109	92	7.0	77.7	65	16	40	3.0	7.0	80	100-109	5.0
964730	16	48	80	6	90-109	92	7.0	83.7	65	16	40	3.0	7.0	80	100-109	5.0
964732	19	51.6	80	5	90-109	92	7.0	77.7	65	16	40	3.0	7.0	80	100-109	5.0
964723	19	57	110	11	126-150	125/92	10.0	88.2	65	16	40	3.0	7.0	70	90-109	5.0
964719	19	40.7	2.875"	5	90-109	92	7.0	77.7	65	16	40	3.0	7.0	70	90-109	5.0
964733	19	51	80	5	90-109	92	7.0	84.2	65	19	40	3.0	7.0	80	100-109	6.0

All dimensions shown in millimeters unless otherwise specified.

Servomotor Brake Approximate Dimensions (IEC Square Flange Motors: size 4)

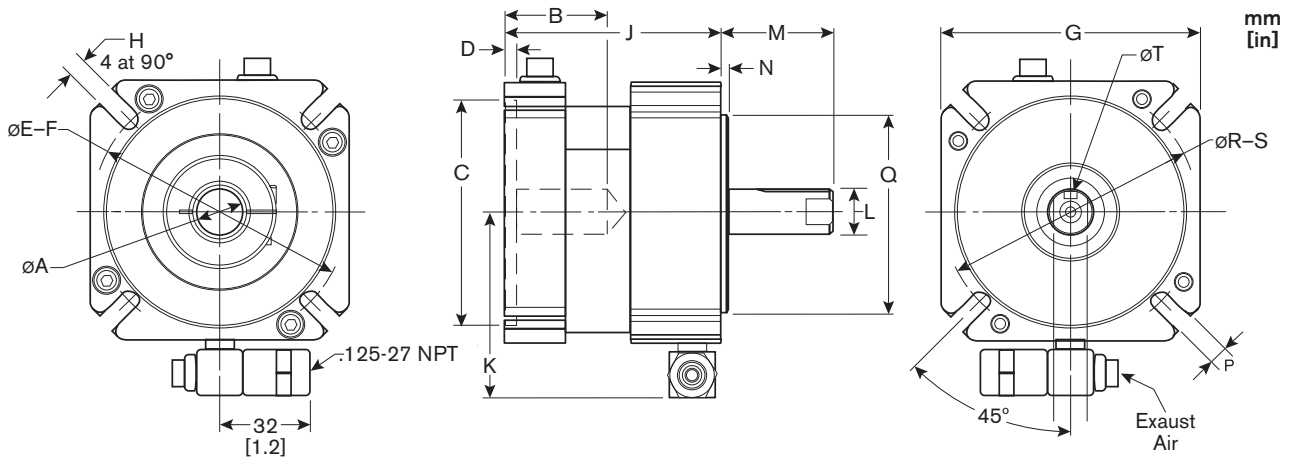

Size 4

Product Number	BORE DIA.	BORE DEPTH	PILOT (female)	PILOT DEPTH	BOLT CIRCLE DIAMETER	FLANGE WIDTH	BOLT HOLE	LENGTH	QUICK EXHAUST	SHAFT DIA.	SHAFT LENGTH	PILOT EXT.	BOLT HOLE	PILOT (male)	BOLT CIRCLE DIAMETER	KEYWAY
	A	B	C	D	E-F	G	H	J	K	L	M	N	P	Q	R-S	T
964865	14	36	80	3.5	115-150	125	10.0	105.7	82	14	20.5	2.3	10.0	80	115-150	none
964867	14	63	95	6	115-150	125	10.0	113.2	82	14	36	2.3	10.0	95	115-150	5.0
964824	14	55.5	80	3.5	115-150	125	10.0	105.7	82	14	30	2.3	10.0	80	115-150	5.0
964852	16	56.3	110	3.5	126-150	125	10.0	105.7	82	16	40	2.3	10.0	110	130-150	5.0
964834	0.625"	56.1	2.500"	3.5	127-150	125	10.0	107.4	82	0.625"	2.000"	2.5	10.0	2.500"	127-150	0.188"
964826	0.625"	56.2	4.500"	3.5	5.875"	125	0.405"	106.5	82	19	40	2.3	10.0	110	130-150	6.0
964818	19	55.5	95	3.5	115-150	125	10.0	105.7	82	19	40	2.3	10.0	95	115-150	6.0
964823	19	55.5	95	3.5	115-150	125	10.0	105.7	82	19	40	2.3	10.0	95	115-150	6.0
964843	19	55.5	95	3.5	115-150	125	10.0	105.7	82	19	40	2.3	10.0	96	115-150	6.0
964866	19	55.6	110	3.5	126-150	125	10.0	106.5	82	19	70	2.3	10.0	110	130-150	6.0
964864	19	55.6	110	3.5	126-150	125	10.0	106.5	82	19	70	2.3	10.0	110	130-150	6.0
964826	0.625"	56.3	4.500"	3.5	5.875"	125	0.405"	106.5	82	19	40	2.3	10.0	110	130-150	6.0
964837	19	56.3	110	3.5	126-150	125	10.0	106.5	82	19	40	2.3	10.0	110	130-150	6.0
964814	19	55.5	110	3.5	126-150	125	10.0	106.5	82	19	50	2.3	10.0	110	130-150	6.0
964819	19	55.5	110	3.5	126-150	125	10.0	106.5	82	19	50	2.3	10.0	110	130-150	6.0
964832	19	60.5	95	3.5	115-150	125	10.0	105.7	82	19	55	2.3	10.0	95	115-150	6.0
964844	19	61.3	110	7	126-150	125	10.0	106.5	82	19	55	2.3	10.0	110	130-150	6.0
964856	19	64.5	110	16	126-150	125	10.0	115.5	82	19	50	2.3	10.0	110	130-150	6.0
964838	19	60.5	95	3.5	115-150	125	10.0	105.7	82	20	62	2.3	10.0	95	115-130	none
964849	19	60.5	95	3.5	115	125/150	.375-16	105.7	95	24	50	2.3	10.0	130	165-186	8.0
964851	19	70.3	110	16	126-150	125	10.0	115.5	82	24	50	2.3	10.0	110	130-150	8.0
964839	19	55.6	95	3.5	115-150	125	10.0	104.8	82	0.625"	2.063"	4.1	.375-16	4.500"	5.875"	0.188"
964816	19	42.9	95	3	126-150	125	10.0	104	82	0.875"	2.125"	4.1	.375-16	4.500"	5.875"	0.188"
964820	22	55.5	110	3.5	126-150	125	10.0	105.6	82	0.625"	2.063"	4.1	.375-16	4.500"	5.875"	0.188"
964821	22	67.1	110	3.5	126-150	125	10.0	99.2	82	22	50	2.3	10.0	110	130-150	6.0
964822	22	73.5	110	6.5	145	125	9.0	124.5	79	22	58	6.0	10.0	110	130-150	6.0
964836	24	56.5	110	3.5	126-150	125	10.0	105.6	82	0.875"	2.125"	4.1	.375-16	4.500"	5.875"	0.188"
964815	24	55.9	110	4	150-186	150/125	12.0	105	82	0.875"	2.125"	4.1	.375-16	4.500"	5.875"	0.188"
964817	24	55.5	110	3.5	126-150	125	10.0	106.5	82	24	50	2.3	10	110	130-150	0.188"
964851	19	70.3	110	16	126-150	125	10.0	115.5	82	24	50	2.3	10.0	110	130-150	8.0
964842	28	67.1	110	7	126-150	125	10.0	106.5	82	28	60	2.3	10.0	110	130-150	none
964848	24	59	110	7	126-150	125	10.0	106.5	82	24	50	2.3	10.0	110	130-150	8.0
964853	24	55.5	110	3.5	126-150	125	10.0	106.5	82	19	35	2.3	10.0	110	130-150	6.0
964830	24	54.7	95	3.5	115-150	125	10.0	105.7	82	24	45	2.3	7.0	95	115-150	8.0
964825	24	54.7	95	3.5	115-150	125	10.0	105.7	82	24	50	2.3	10.0	95	115-150	8.0
964828	24	55.5	110	3.5	126-150	125	10.0	106.5	95	24	50	2.3	10.0	110	130-150	8.0
964829	24	55.5	110	3.5	126-150	125	10.0	106.5	82	24	50	2.3	10.0	110	130-150	8.0
964860	24	58.1	110	3.5	126-150	125	10.0	106.5	82	24	50	2.3	10.0	110	130-150	8.0
964855	28	85.7	110	7	126-150	125	10.0	125	82	28	60	2.3	10.0	110	130-150	none

All dimensions shown in millimeters unless otherwise specified.

Servomotor Brake Approximate Dimensions (IEC Square Flange Motors: size 5)

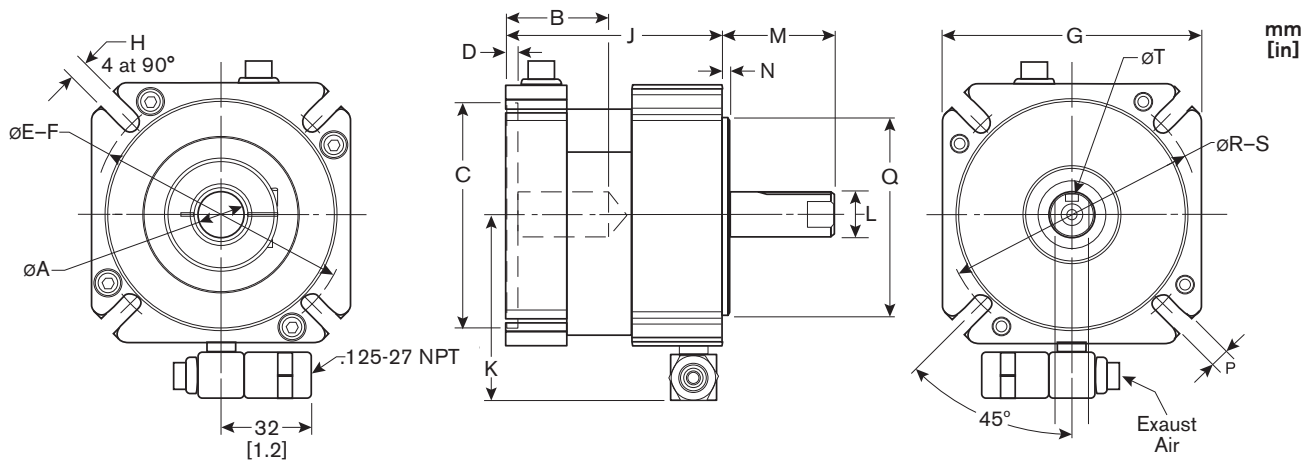

Size 5

Product Number	BORE DIA.	BORE DEPTH	PILOT (female)	PILOT DEPTH	BOLT CIRCLE DIAMETER	FLANGE WIDTH	BOLT HOLE	LENGTH	QUICK EXHAUST	SHAFT DIA.	SHAFT LENGTH	PILOT EXT.	BOLT HOLE	PILOT (male)	BOLT CIRCLE DIAMETER	KEYWAY
	A	B	C	D	E-F	G	H	J	K	L	M	N	P	Q	R-S	T
964933	24	63	110	6.2	130	150.5	M8	132.5	95	24	50	2.4	12.0	110	165-186	8.0
964934	24	63	110	6.2	145	150.4	M8	132.5	95	24	50	2.4	12.0	110	165-186	8.0
964909	24	58	110	6.2	150-186	150.4	12.0	132.5	95	24	50	2.4	12.0	110	165-186	8.0
964913	24	58	110	6.2	150-186	150.4	12.0	132.5	95	24	50	2.4	12.0	110	165-186	8.0
964907	24	58	130	6.2	150-186	150.4	12.0	132.5	95	24	50	2.4	12.0	130	165-186	8.0
964908	24	58	130	6.2	150-186	150.4	12.0	132.5	95	24	50	2.4	12.0	130	165-186	8.0
964930	24/kwy	66.7	110	6.2	150-186	150.4	12.0	132.5	95	24	50	2.4	12.0	110	165-186	8.0
964912	24	66.7	130	6.2	150-186	150.4	12.0	132.5	95	24	50	2.4	12.0	130	165-186	8.0
964916	24	64	130	6.2	150-186	150.4	12.0	131.9	95	0.875"	2.125"	4.1	.375-16	4.500"	5.875"	0.188"
964923	24	58	130	6.2	150-186	150.4	12.0	131.9	95	1.062"	1.950"	4.1	.375-16	4.500"	5.875"	0.250"
964917	1.125"	60.5	4.500"	6.2	150-186	150.4	12.0	132.5	95	24	50	2.4	12.0	110	165-186	8.0
964929	28	66.7	130	6.2	150-186	150.4	12.0	132.5	95	24	50	2.4	12.0	130	165-186	8.0
964915	28	66.7	130	6.2	150-186	150.4	12.0	132.5	95	28	60	2.4	12.0	130	165-186	8.0
964920	28	66.7	130	6.2	150-186	150.4	12.0	132.5	95	28	60	2.4	12.0	130	165-186	8.0
964928	28	66.7	130	6.2	150-186	150.4	12.0	131.9	95	1.062"	1.950"	4.1	.375-16	4.500"	5.875"	0.250"
964932	28	71.7	130	6.2	150-186	150.4	12.0	132.5	95	28	60	2.4	12.0	130	165-186	8.0
964918	32	58	130	6.2	150-186	150.4	12.0	132.5	95	32	54	2.4	12.0	130	165-186	10.0
964931	32	58	130	6.2	150-186	150.4	12.0	132.5	95	32	54	2.4	12.0	130	165-186	10.0
964925	32	82	130	6.2	150-186	150.4	12.0	132.5	95	24	50	2.4	12.0	130	165-186	none
964906	32	65.7	130	4.0	215	178/150.4	15.0	140.5	95	0.875"	2.125"	4.1	.375-16	4.500"	5.875"	0.188"
964921	32	75.2	130	4.0	215	178/150.4	15.0	141	95	32	60	2.4	12.0	130	165-186	10.0
964919	32	66.7	130	6.2	150-186	150.4	12.0	132.5	95	32	60	2.4	12.0	130	165-186	10.0
964937	32/kwy	83	130	6.2	150-186	150.4	12.0	148.5	95	32	80	2.4	12.0	130	165-186	10.0

All dimensions shown in millimeters unless otherwise specified.

Servomotor Brake Approximate Dimensions (IEC Square Flange Motors: size 7)

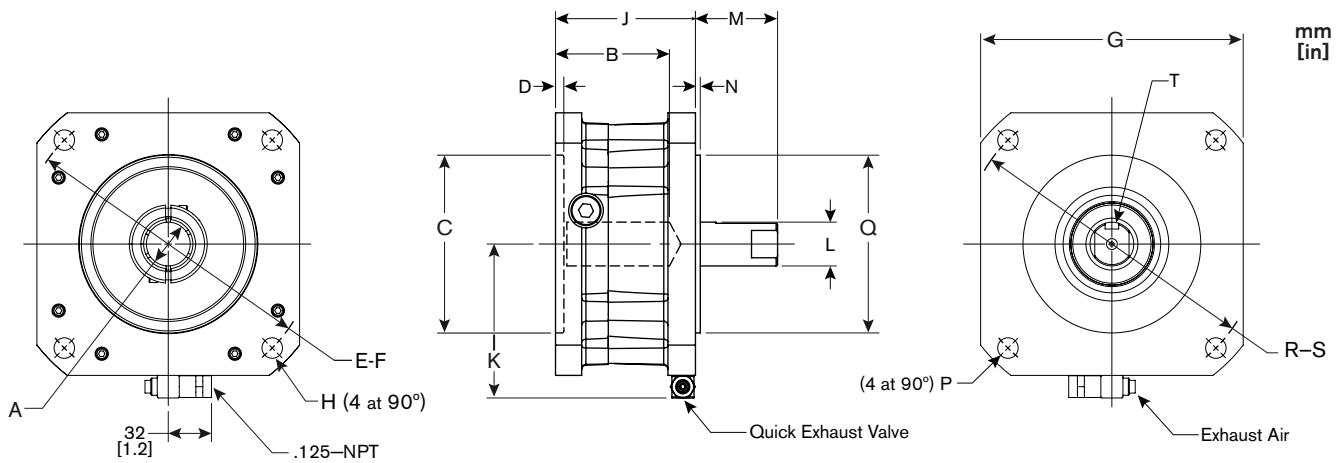

Size 7

Product Number	BORE DIA.	BORE DEPTH	PILOT (female)	PILOT DEPTH	BOLT CIRCLE DIAMETER	FLANGE WIDTH	BOLT HOLE	LENGTH	QUICK EXHAUST	SHAFT DIA.	SHAFT LENGTH	PILOT EXT.	BOLT HOLE	PILOT (male)	BOLT CIRCLE DIAMETER	KEYWAY
	A	B	C	D	E-F	G	H	J	K	L	M	N	P	Q	R-S	T
965008	24	83.2	130	6.1	165	192	M10	102.3	113	24	50	3.5	12.0	130	180	8.0
965010	32	83.2	130	6.1	165	192	M10	102.3	113	32	60	3.5	15.0	130	215	10.0
965001	32	83.2	180	6.1	215	192	15.0	102.3	113	32	60	3.5	15.0	180	215	10.0
965006	32	83.2	180	6.1	215	192	15.0	102.3	113	32	60	3.5	15.0	180	215	10.0
965004	32	83.2	130	6.1	215	192	15.0	102.3	113	32	60	3.5	15.0	130	215	10.0
965014	32	82	130	6.1	165	174	.438-14	102.3	105	1.250"	80	3.2	13.5	4.500"	200	0.250"
965015	1.375"	88.2	4.500"	6.1	200	174	.500-13	102.3	105	1.375"	3.875"	3.2	13.5	4.500"	200	0.314"
965011	1.375"	88.2	4.500"	6.1	200	174	.500-13	102.3	105	1.375"	3.875"	3.2	13.5	4.500"	200	0.314"
965017	1.375"	84.6	4.500"	6.1	7.750"	174	.375-16	102.3	105	1.375"	66.5	3.2	.375-16	4.500"	7.750"	0.314"
965005	35	88.2	4.500"	6.1	200	174	M12	102.3	104	35	79	3.2	13.5	4.500"	200	10.0
965007	32	84.9	180	6.1	215	192	15.0	102.3	NA	1.375"	3.37"	0.250"	.500"	8.500"	7.250"	0.314"
965012	32	83.2	130	6.1	215	192	15.0	102.3	132	1.125"	2.89"	0.250"	.500-13	8.500"	7.250"	0.250"
965014	32	82	130	6.1	165	174	.438-14	102.3	105	1.250"	80	3.2	13.5	4.500"	200	0.250"
965013	32	83.2	130	6.1	215	192	15.0	102.3	113	32	60	3.5	15.0	130	215	10.0
965000	32	83.2	130	6.1	215	192	15.0	102.3	113	32	60	3.5	15.0	130	215	10.0
965026	32/kwy	82.1	130	6.1	215	192	.500-13	102.3	113	35	95	3.5	.500-13	130	215	10.0
965003	35	88.2	4.500"	6.1	200	174	M12	102.3	104	35	79	3.2	13.5	4.500"	200	10.0
965002	35	88.2	4.500"	6.1	200	192	13.0	102.3	113	35	80	3.5	13.0	4.500"	200	10.0
965019	38	83.2	180	6.1	215	192	15.0	102.3	113	38	80	3.5	15.0	180	215	12.0
965009	42	114.1	4.500"	5.0	200	174	12.8	128.2	104	35	79	3.2	13.5	4.500"	200	10.0
965016	42	114.1	4.500"	5.0	200	174	12.8	128.2	104	42	113	3.2	13.5	4.500"	200	12.0
965021	1.188"	88.2	4.500"	6.1	200	192/174	13.0	102.3	104	35	79	3.2	13.5	4.500"	200	10.0
965020	42	114.1	4.500"	5.0	200	174	12.8	128.2	104	42	113	3.2	13.5	4.500"	200	12.0

All dimensions shown in millimeters unless otherwise specified.

Servomotor Brake Approximate Dimensions (IEC Square Flange Motors: sizes 9 & 11)

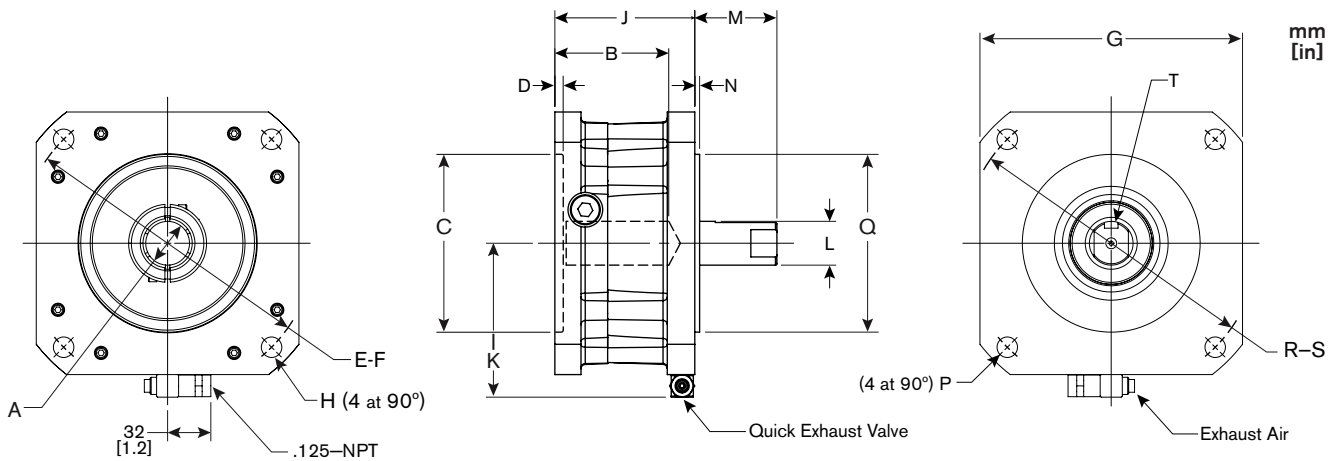

Size 9

Product Number	BORE DIA.	BORE DEPTH	PILOT (female)	PILOT DEPTH	BOLT CIRCLE DIAMETER	FLANGE WIDTH	BOLT HOLE	LENGTH	QUICK EXHAUST	SHAFT DIA.	SHAFT LENGTH	PILOT EXT.	BOLT HOLE	PILOT (male)	BOLT CIRCLE DIAMETER	KEYWAY
	A	B	C	D	E-F	G	H	J	K	L	M	N	P	Q	R-S	T
965100	38	83.2	180	4.1	215	214	13.0	102.3	124	38	60	3.5	13.0	180	215	12.0
965110	38	83.2	180	4.1	215	214	13.0	102.3	124	38	60	3.5	13.0	180	215	10.0
965111	38	83.2	180	4.1	215	214	13.0	102.3	124	38	60	3.5	13.0	180	215	10.0
965102	38	83.2	180	4.1	215	214	13.0	102.3	124	38	60	3.5	13.0	180	215	12.0
965104	38	83.2	180	4.1	215	214	13.0	102.3	124	38	60	3.5	13.0	180	215	12.0
965103	38	83.2	180	4.1	215	214	M14	102.3	124	38	80	3.5	11.0	180	215	12.0
965107	38	83.2	180	4.1	215	214	13.0	102.3	124	38	80	3.5	13.0	180	215	none
965101	38	83.2	180	5.0	215	214	M12	102.3	124	1.375"	60	3.5	13.0	180	215	none
965208	38	83.2	180	5.0	215	214	M12	102.3	124	38	80	3.5	14.0	180	215	12.0
965105	42	117.1	200	5.0	235	220/214	13.5	136.2	124	42	116	3.5	13.5	200	235	12.0
965106	55	117.1	200	5.0	235	220/214	13.5	154.5	124	42	80.9	3.5	14.0	180	8.434"	12.0

Size 11

Product Number	BORE DIA.	BORE DEPTH	PILOT (female)	PILOT DEPTH	BOLT CIRCLE DIAMETER	FLANGE WIDTH	BOLT HOLE	LENGTH	QUICK EXHAUST	SHAFT DIA.	SHAFT LENGTH	PILOT EXT.	BOLT HOLE	PILOT (male)	BOLT CIRCLE DIAMETER	KEYWAY
	A	B	C	D	E-F	G	H	J	K	L	M	N	P	Q	R-S	T
965201	35	92.1	230	9.1	265	262.9	M12	123.3	158	35	92	5.0	14.0	230	265	None
965202	42	110.1	230	5	265	262.9	12.8	143.3	148	42	92	5.0	14.0	230	265	12.0
965204	42/kyw	106.56	250	9.1	300	262.9	.625-11	123.3	148	45	100	5.0	.625-11	250	300	14.0
965200	48	91.56	250	9.1	300	262.9	15.0	123.3	148	48	60	5.0	15.0	250	300	14.0
965205	48	91.56	250	9.1	300	262.9	15.0	123.3	148	48	60	5.0	15.0	250	300	14.0
965203	48	91.56	250	9.1	300	262.9	15.0	123.3	148	48	82	5.0	15.0	250	300	14.0

All dimensions shown in millimeters unless otherwise specified.

Eclipse® Performance

Eclipse® Servomotor Brakes Deliver: High Torque • High Torsional Rigidity • Low Inertia

Servomotor Brake Specifications

NEMA Square Flange Compatible

Product Number	Static Torque	Transmittable Torque	Torsional Rigidity	Engage Time	Release Time	Max RPM	Overhung Load	Shaft Inertia	Minimum Release Pressure
	in-lbf	in-lbf	lbf-ft/rad	msec	msec		lbf	lbf-ft ²	psi
Nexen Model SBP-2 for NEMA 23									
964606	20	20	1,000	8	92	10,000	Not Recommended	0.0005	80
964611	20	20	1,000	8	92	10,000		0.0005	80
964605	20	20	1,000	8	92	10,000		0.0005	80
Nexen Model SBP-3 for NEMA 34									
964729	70	70	3,900	12	75	10,000	240	0.0012	80
964728	70	70	3,900	12	75	10,000	240	0.0012	80
964722	70	70	3,900	12	75	10,000	240	0.0012	80
964726	70	70	5,700	12	75	10,000	240	0.0012	80
Nexen Model SBP-4 for NEMA 42									
964833	200	200	6,200	50	80	10,000	210	0.0074	80
964835	200	200	6,200	50	80	10,000	210	0.0074	80

Metric Square Flange Sizes

Product Number	Static Torque	Transmittable Torque	Torsional Rigidity	Engage Time	Release Time	Max RPM	Overhung Load	Shaft Inertia	Minimum Release Pressure
	Nm	Nm	Nm/rad	msec	msec		Newtons	kg•m ²	bar
Size 2									
964610	2.3	2.3	1,000	8	92	10,000	Not Recommended	0.00002	5.5
964615	2.3	2.3	1,000	8	92	10,000		0.00002	5.5
964612	2.3	2.3	1,000	8	92	10,000		0.00002	5.5
964617	2.3	2.3	2,700	8	92	10,000	845	0.00002	5.5
964614	2.3	2.3	2,700	8	92	10,000	845	0.00002	5.5
964613	2.3	2.3	3,700	8	92	10,000	845	0.00002	5.5
Size 3									
964721	5.0	7.9	1,800	12	75	10,000	400	0.00005	3.4
964717	7.9	7.9	3,900	12	75	10,000	1,070	0.00005	5.5
964713	5.0	7.9	4,500	12	75	10,000	1,070	0.00005	3.4
964714	7.9	7.9	4,500	12	75	10,000	1,070	0.00005	5.5
964709	7.9	7.9	4,500	12	75	10,000	1,070	0.00005	5.5
964710	5.0	7.9	4,500	12	75	10,000	1,070	0.00005	3.4
964724	5.0	7.9	4,500	12	75	10,000	1,070	0.00005	3.4
964718	7.9	7.9	4,500	12	75	10,000	1,070	0.00005	5.5
964725	7.9	7.9	4,500	12	75	10,000	1,070	0.00005	5.5
964727	7.9	7.9	4,500	12	75	10,000	1,070	0.00005	5.5
964716	7.9	7.9	5,700	12	75	10,000	1,070	0.00005	5.5
964720	5.0	7.9	5,700	12	75	10,000	1,070	0.00005	3.4
964712	7.9	7.9	5,700	12	75	10,000	1,070	0.00005	5.5
964711	7.9	7.9	5,700	12	75	10,000	1,070	0.00005	5.5
964715	7.9	7.9	5,700	12	75	10,000	1,070	0.00005	5.5
964730	7.9	7.9	5,700	12	75	10,000	1,070	0.00005	5.5
964732	7.9	7.9	7,200	12	75	10,000	1,070	0.00005	5.5
964723	5.0	7.9	7,200	12	75	10,000	1,070	0.00005	3.4
964719	7.9	7.9	7,200	12	75	10,000	1,070	0.00005	5.5
964733	8.0	8.0	11,500	12	75	10,000	1,070	0.00005	5.5

See appendix for specification definitions.

Specifications

Servomotor Brake Specifications (metric size 4)

Product Number	Static Torque	Transmittable Torque	Torsional Rigidity	Engage Time	Release Time	Max RPM	Overhung Load	Shaft Inertia	Minimum Release Pressure
	Nm	Nm	Nm/rad	msec	msec		Newtons	kgm ²	bar
Size 4									
964865	22	22	4,300	50	80	10,000	845	0.00027	5.5
964867	22	22	4,300	50	80	10,000	845	0.00027	5.5
964824	22	22	4,300	50	80	10,000	845	0.00027	5.5
964852	22	22	6,200	50	80	10,000	1,423	0.00027	5.5
964834	22	22	6,200	50	80	10,000	934	0.00027	5.5
964826	22	22	6,200	50	80	10,000	2,334	0.00027	5.5
964818	22	22	11,800	50	80	10,000	2,334	0.00031	5.5
964823	14.1	22	11,800	50	80	10,000	2,334	0.00031	3.4
964843	22.6	22	11,800	50	80	10,000	2,334	0.00031	5.5
964866	22.6	22	11,800	50	80	10,000	1,423	0.00031	5.5
964864	14.1	22	11,800	50	80	10,000	1,423	0.00031	3.4
964826	22.6	22	11,800	50	80	10,000	2,334	0.00031	5.5
964837	22.6	22	11,800	50	80	10,000	2,334	0.00031	5.5
964814	22.6	22	11,800	50	80	10,000	1,780	0.00031	5.5
964819	14.1	22	11,800	50	80	10,000	1,780	0.00031	3.4
964832	22.6	22	11,800	50	80	10,000	1,780	0.00031	5.5
964844	22.6	22	11,800	50	80	10,000	1,780	0.00031	5.5
964856	22.6	22	11,800	50	80	10,000	1,780	0.00031	5.5
964838	22.6	22	11,800	50	80	10,000	1,780	0.00031	5.5
964849	22.6	22	20,700	50	80	10,000	2,334	0.00031	5.5
964851	22.6	22	20,700	50	80	10,000	2,334	0.00031	5.5
964839	22.6	22	11,800	50	80	10,000	934	0.00031	5.5
964816	22.6	22	11,800	50	80	10,000	2,334	0.00031	5.5
964820	22.6	22	16,300	50	80	10,000	934	0.00031	5.5
964821	22.6	22	16,300	50	80	10,000	2,334	0.00031	5.5
964822	14.1	22	16,300	50	80	10,000	2,334	0.00031	3.4
964836	22.6	22	20,700	50	80	10,000	2,334	0.00031	5.5
964815	22.6	22	20,700	50	80	10,000	2,334	0.00031	5.5
964817	22.6	22	20,700	50	80	10,000	2,334	0.00031	5.5
964851	22.6	22	20,700	50	80	10,000	2,334	0.00031	5.5
964842	22.6	22	37,000	50	80	10,000	2,334	0.00041	5.5
964848	22.6	22	20,700	50	80	10,000	2,334	0.00031	5.5
964853	22.6	22	20,700	50	80	10,000	2,334	0.00031	5.5
964830	22.6	22	20,700	50	80	10,000	2,334	0.00031	5.5
964825	22.6	22	20,700	50	80	10,000	2,334	0.00031	5.5
964828	22.6	22	20,700	50	80	10,000	2,334	0.00031	5.5
964829	14.1	22	20,700	50	80	10,000	2,334	0.00031	3.4
964860	22.6	22	20,700	50	80	10,000	2,334	0.00031	5.5
964855	22.6	22	37,000	50	80	10,000	2,334	0.00041	5.5

Servomotor Brake Specifications (metric size 5 & 7)

Product Number	Static Torque	Transmittable Torque	Torsional Rigidity	Engage Time	Release Time	Max RPM	Overhung Load	Shaft Inertia	Minimum Release Pressure
	Nm	Nm	Nm/rad	msec	msec		Newtons	kg•m ²	bar
Size 5									
964933	45	45	20,600	60	100	10,000	NOTE: These models are intended for direct mounting. Side loading is not recommended. Consult Nexen Engineering with questions.	0.00117	5.5
964934	45	45	20,600	60	100	10,000		0.00117	5.5
964909	45	45	20,600	60	100	10,000		0.00117	5.5
964913	28.3	45	20,600	60	100	10,000		0.00117	3.4
964907	45	45	20,600	60	100	10,000		0.00117	5.5
964908	28.3	45	20,600	60	100	10,000		0.00117	3.4
964930	45	45	20,600	60	100	10,000		0.00117	5.5
964912	45	45	20,600	60	100	10,000		0.00117	5.5
964916	45	45	20,600	60	100	10,000		0.00117	5.5
964923	45	45	20,600	60	100	10,000		0.00117	5.5
964917	45	45	40,000	60	100	10,000		0.00130	5.5
964929	45	45	40,000	60	100	10,000		0.00130	5.5
964915	28.3	45	40,000	60	100	10,000		0.00130	3.4
964920	45	45	40,000	60	100	10,000		0.00130	5.5
964928	45	45	40,000	60	100	10,000		0.00130	5.5
964932	45	45	40,000	60	100	10,000		0.00130	5.5
964918	45	45	52,400	60	100	10,000		0.00130	5.5
964931	45	45	52,400	60	100	10,000		0.00130	3.4
964925	45	45	52,400	60	100	10,000		0.00130	5.5
964906	45	45	52,400	60	100	10,000		0.00130	5.5
964921	45	45	52,400	60	100	10,000	0.00130	5.5	
964919	45	45	52,400	60	100	10,000	0.00130	5.5	
964937	45	150	54,200	60	100	10,000	3100	0.00159	5.5
Size 7									
965008	100	100	24,600	85	145	5,000	NOTE: These models are intended for direct mounting. Side loading is not recommended. Consult Nexen Engineering with questions.	0.00325	4.4
965010	100	125	55,300	85	145	5,000		0.00333	4.4
965001	125	125	55,300	85	145	5,000		0.00333	5.5
965006	100	125	55,300	85	145	5,000		0.00333	4.4
965004	75	125	55,300	85	145	5,000		0.00333	3.3
965014	125	125	55,300	85	145	5,000		0.00333	5.5
965015	125	125	83,300	85	145	5,000		0.00346	5.5
965011	75	125	83,300	85	145	5,000		0.00346	3.3
965017	125	125	83,300	85	145	5,000		0.00346	5.5
965005	125	125	76,500	85	145	5,000		0.00346	5.5
965007	125	125	55,300	85	145	5,000		0.00333	5.5
965012	75	125	55,300	85	145	5,000		0.00333	3.3
965014	125	125	55,300	85	145	5,000		0.00333	5.5
965013	125	125	55,300	85	145	5,000		0.00333	5.5
965000	125	125	55,300	85	145	5,000		0.00333	5.5
965026	125	150	76,500	85	145	5,000		0.00352	5.5
965003	75	125	76,500	85	145	5,000		0.00346	3.3
965002	50	125	76,500	85	145	5,000		0.00346	2.2
965019	87	125	98,700	85	145	5,000		0.00362	3.9
965009	125	125	108,600	85	145	5,000		0.00379	5.5
965016	125	125	108,600	85	145	5,000	0.00379	5.5	
965021	75	100	65,800	85	145	5,000	0.0034	3.3	
965020	100	125	108,600	85	145	5,000	0.00379	4.4	

See appendix for specification definitions.

Servomotor Brake Specifications (metric size 9 & 11)

Product Number	Static Torque	Transmittable Torque	Torsional Rigidity	Engage Time	Release Time	Max RPM	Overhung Load	Shaft Inertia	Minimum Release Pressure
	Nm	Nm	Nm/rad	msec	msec		Newtons	kgm ²	bar
Size 9									
965100	125	125	114,000	85	145	5,000	NOTE: These models are intended for direct mounting. Side loading is not recommended. Consult Nexen Engineering with questions.	0.00362	5.5
965110	125	125	114,000	85	145	5,000		0.00362	5.5
965111	50	125	114,000	85	145	5,000		0.00362	2.2
965102	75	125	114,000	85	145	5,000		0.00362	3.3
965104	100	125	114,000	85	145	5,000		0.00362	4.4
965103	125	125	97,900	85	145	5,000		0.00362	5.5
965107	125	125	97,900	85	145	5,000		0.00362	5.5
965101	100	125	97,900	85	145	5,000		0.00362	4.4
965208	100	125	97,900	85	145	5,000		0.00362	4.4
965105	125	125	119,000	85	145	5,000		0.00379	5.5
965106	125	125	188,000	85	145	5,000	0.00554	5.5	
Size 11									
965201	75	125	63,600	85	145	5,000	NOTE: Intended for direct mounting. Side loading is not recommended.	0.00346	3.3
965202	75	125	156,000	85	145	5,000		0.00379	3.3
965204	125	125	156,000	85	145	5,000		0.00379	5.5
965200	125	125	216,000	85	145	5,000		0.00404	5.5
965205	100	125	216,000	85	145	5,000		0.00404	4.4
965203	125	125	216,000	85	145	5,000		0.00411	5.5

See appendix for specification definitions.

Optional Solenoid Valve

Nexen's optional solenoid valve offers machine operators additional safety and peace of mind by allowing users to see at a glance whether or not the brake is disengaged. The manual override button provides an easy option for manual brake disengagement.

Nexen's solenoid valve mounts easily on any Eclipse® servomotor brake and operates using standard 80 PSIG compressed air and 24VDC controls.

- Visual Disengagement Indication
- Manual Disengagement Button
- Simple Connections:
 - 24VDC control
 - 80 PSIG shop air

PRODUCT NUMBER: 964650

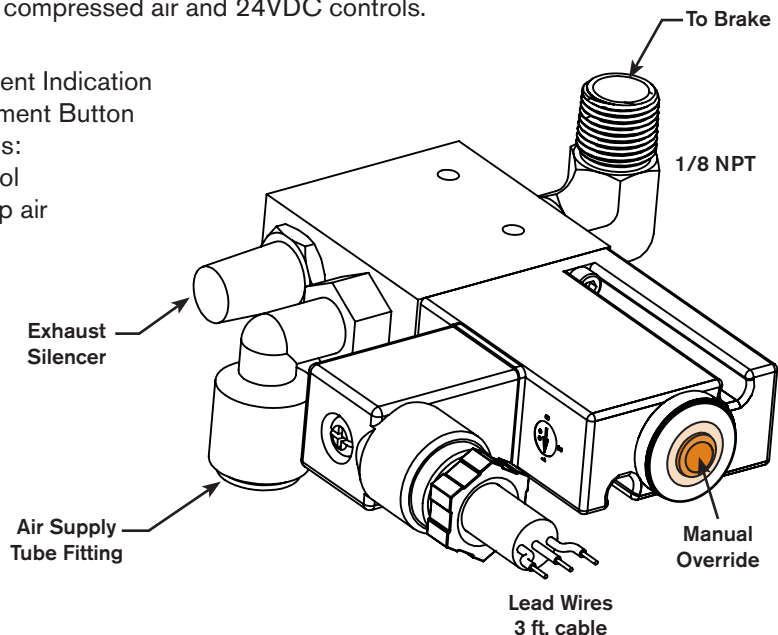

BACKLASH

Because zero backlash is impossible to measure, industry standard maintains that anything under 3.2 microns is considered zero.

The Eclipse® line of servomotor brakes have two design features that facilitate backlash-free performance. Both the keyless, split-hub clamping collar and the one piece rotor/shaft work to create a backlash free environment. The unique rotor/shaft actually lowers inertia and minimizes moving parts.

CORROSION RESISTANCE

Nexen offers various corrosion countermeasures that include stainless steel and various surface treatments or coatings. Nexen will convey all material and coating specifications, but it is up to the customer to determine application suitability based on this information and/or thorough sample testing. Nexen makes no corrosion resistance claims for specific applications.

TRANSMITTABLE TORQUE

Transmittable torque is the maximum amount of torque that can be passed from a motor through the brake and into a gearbox or other output. Transmittable torque accounts for clamp-collar holding force and output shaft strength.

IP67 DUST & WATERPROOF STANDARDS

This international rating was developed to provide machine builders with standards by which to properly select products to operate in specific conditions. Nexen's Eclipse® line of Servomotor Brakes are completely enclosed and offer highest standard of protection against dust and water. They have been independently tested to withstand full immersion in water for up to 30 minutes at a depth of up to 1 meter and can withstand even the dirtiest environments with no degradation on efficiency, performance or life of the brake.

LUBRICATION FREE OPERATION

Operating without lubrication can be beneficial in food, pharmaceutical, clean room, and other applications where the grease could contaminate the environment, or applications with high levels environmental contaminants that would be attracted to the grease and accelerate the wear rate.

OVERHUNG LOAD (also called Side Loading)

In overhung load applications the force of the load is applied to the shaft beyond the support point and is perpendicular to the shaft. Nexen ratings assume the load is applied at the shaft extension midpoint. Not all brakes are suitable for overhung loads. Refer to product specifications to determine suitability.

TORSIONAL RIGIDITY

Nexen Eclipse® Servomotor Brakes offer high torsional rigidity, meaning they can withstand a great amount of twisting force without it affecting performance. High torsional rigidity is beneficial in any system where precision positioning is required.

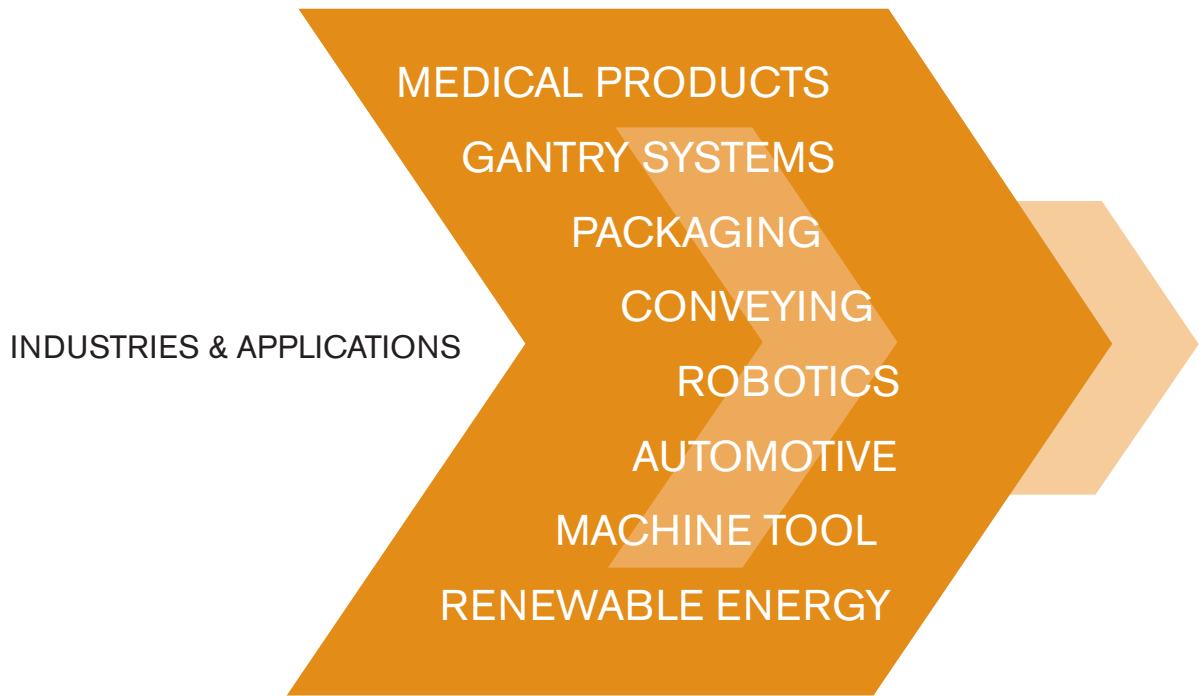

www.nexengroup.com

In accordance with Nexen's established policy of constant product improvement, the specifications contained in this document are subject to change without notice. Technical data listed in this document are based on the latest information available at the time of printing and are also subject to change without notice. For current information, please consult www.nexengroup.com or contact Nexen's Technical Support Group at the location to the right.

nexen[®]

Nexen Group, Inc. (800) 843-7445
560 Oak Grove Parkway Fax: (651) 286-1099
Vadnais Heights, MN 55127 www.nexengroup.com

Nexen has sales offices throughout the United States, Europe, Japan, and Australia.